

# CU1526, CU2026, CU3030 Service Parts

This is the illustrated list of service parts for all models of the CU1526, CU2026 and CU3030 self-contained ice machines.

These machines were manufactured in several voltages, which is designated by a numeric voltage-code at the end of the model number. The complete model number ends in a series code (alpha), which may also be important for changes during production. Use the complete model number to be sure of obtaining the correct replacement part.

## Voltage codes:

- -1 = 115 volts, 60 Hz, single phase
- -6 = 230 volts, 50 Hz, single phase
- -32 = 208-230 volts, 60 Hz, single phase

## Table of Contents

CU1526 and CU2026 Cabinet .....	Page 2
CU1526 and CU2026 Back and Base .....	Page 3
CU1526, CU2026 Pump, Float Valve, Water Sensor, Purge Valve .....	Page 4
CU1526 and CU2026 Air Cooled Refrigeration .....	Page 5
CU1526 and CU2026 Water Cooled Refrigeration.....	Page 6
CU1526 and CU2026 Ice Making Area .....	Page 7
CU1526 and CU2026 Electrical .....	Page 8
CU3030 Cabinet .....	Page 9
CU3030 Back and Base .....	Page 10
CU3030 Pump, Float Valve, Water Sensor, Purge Valve .....	Page 11
CU3030 Air Cooled Refrigeration .....	Page 12
CU3030 Water Cooled Refrigeration.....	Page 13
CU3030 Ice Making Area.....	Page 14
CU3030 Electrical .....	Page 15

# CU1526, CU2026, CU3030 Service Parts

## CU1526 and CU2026 Cabinet

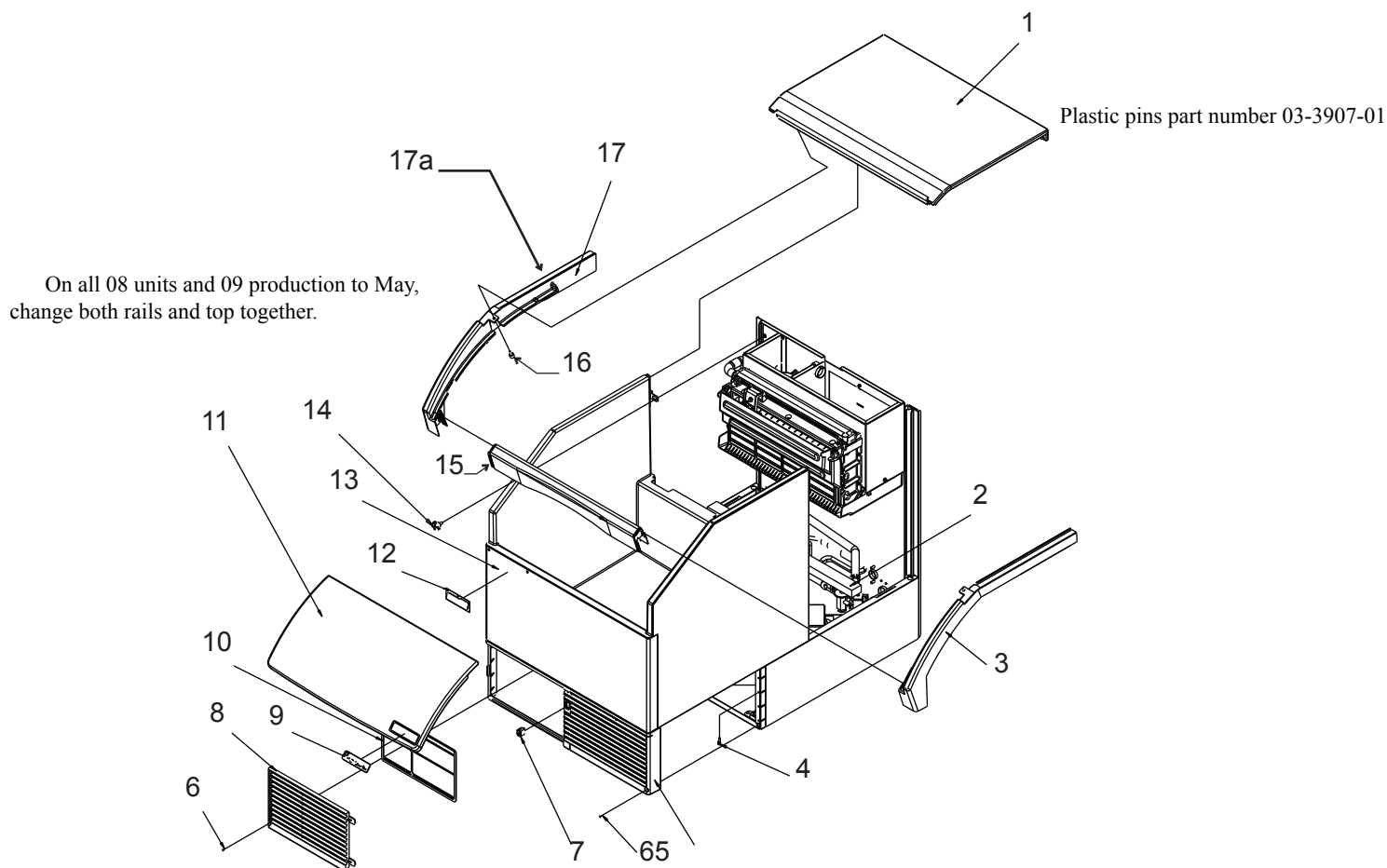

Item	Part Number	Description
------	-------------	-------------

1	A39132-001	Top panel
2	19-0655-01	Gasket
3	02-4310-04	Right rail, 26" model
4	03-0727-10	Thumb screw
5	02-4304-01	Right grill & frame, 26" model*
6	03-1404-12	Screw
7	12-2991-01	On/Off switch - discontinued
8	02-4304-02	Left grill, 26" model
9	15-0825-01	Emblem
10	02-4308-01	Air filter (AC only)
11	02-4306-20	Door, 26" model
12	15-0824-01	Prodigy logo
13	A39120-021	Bin assembly, includes items 3, 12, 15, 17
14	03-1675-02	3 prong head screw
15	02-4312-01	Frame front, 26" model
16	03-3892-01	Screw, bin to top
17	02-4310-03	Left rail, 26" model
17a	03-1419-17	Flat head screw for rail

Not Shown

NS1	02-3253-01	Scoop
NS1	KLP7	Legs - set of 4
NS3	16-1150-01	Fitting, water 50 Hz
NS4	03-3901-01	Washer, 50 Hz

Note: Frame rail attachment to bin wall changed late2008 from adhesive only to screws and adhesive. Screw used is #6 x 5/8 flat head. When replacing frame rail on prior bin, use 1/8" dia drill bit to create mounting holes in top of bin wall.

\* Part changed CU1526SA-1A serial number12021320013140, started 2-22-2012, no spot for on-off switch. If replacing grill on unit with switch, mount switch to notch in access valve bracket.

**CU1526, CU2026, CU3030 Service Parts  
CU1526 and CU2026 Back and Base**

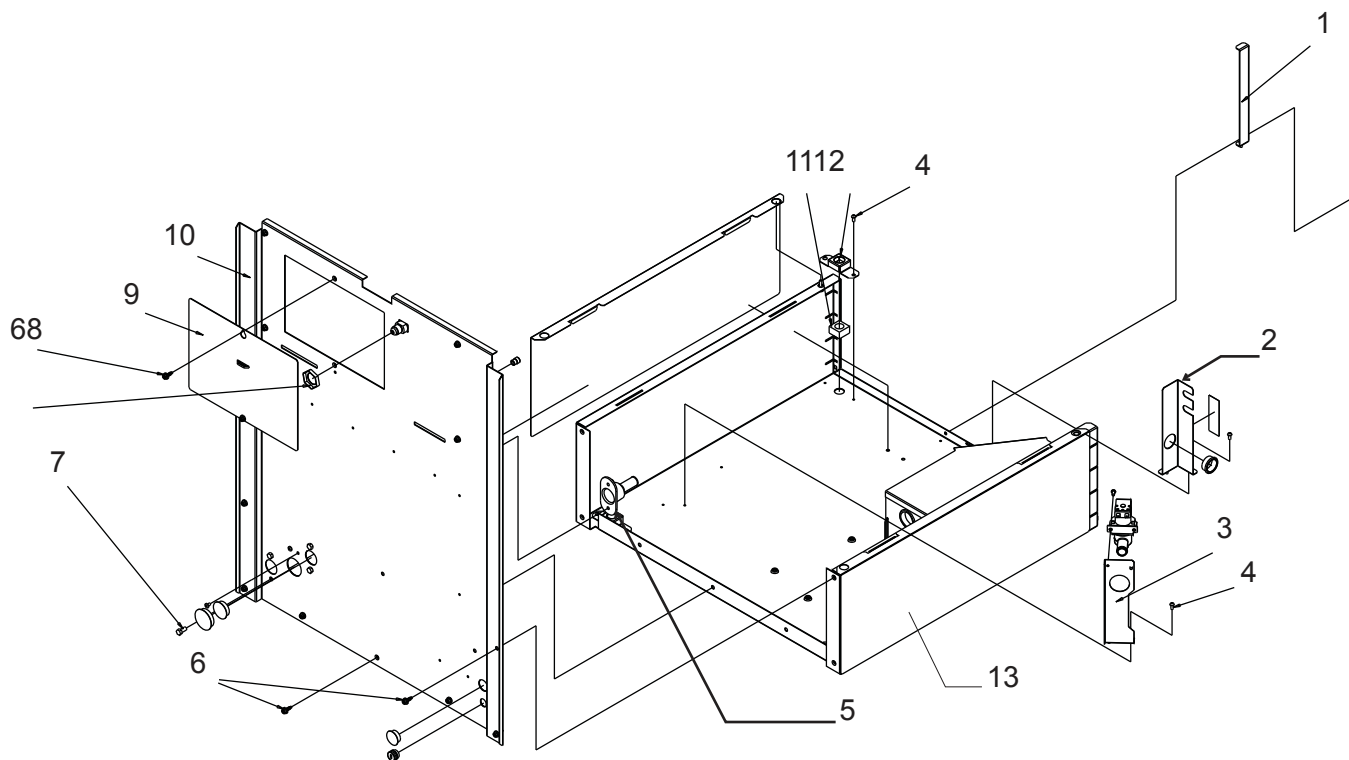

Item	Part Number	Description
1	A39145-001	Baffle, AC
2	A39086-001	Bracket, access valves
3	A39092-001	Bracket, purge valve
4	03-1531-01	Screw
5	02-3692-21	Drain fitting
6	03-3868-01	Screw
7	03-0571-00	Screw
8	03-1394-01	Pal nut
9	A39142-001	Service panel
10	A40252-001	Back panel
11	03-1674-01	Nut, leg mounting
12	A39083-001	Bracket, nut
13	A39089-001	Overlay panel, attach with adhesive tape, item 13a, 2 feet
13a	19-0642-02	Adhesive tape, order by foot.

# CU1526, CU2026, CU3030 Service Parts

## CU1526, CU2026 Pump, Float Valve, Water Sensor, Purge Valve

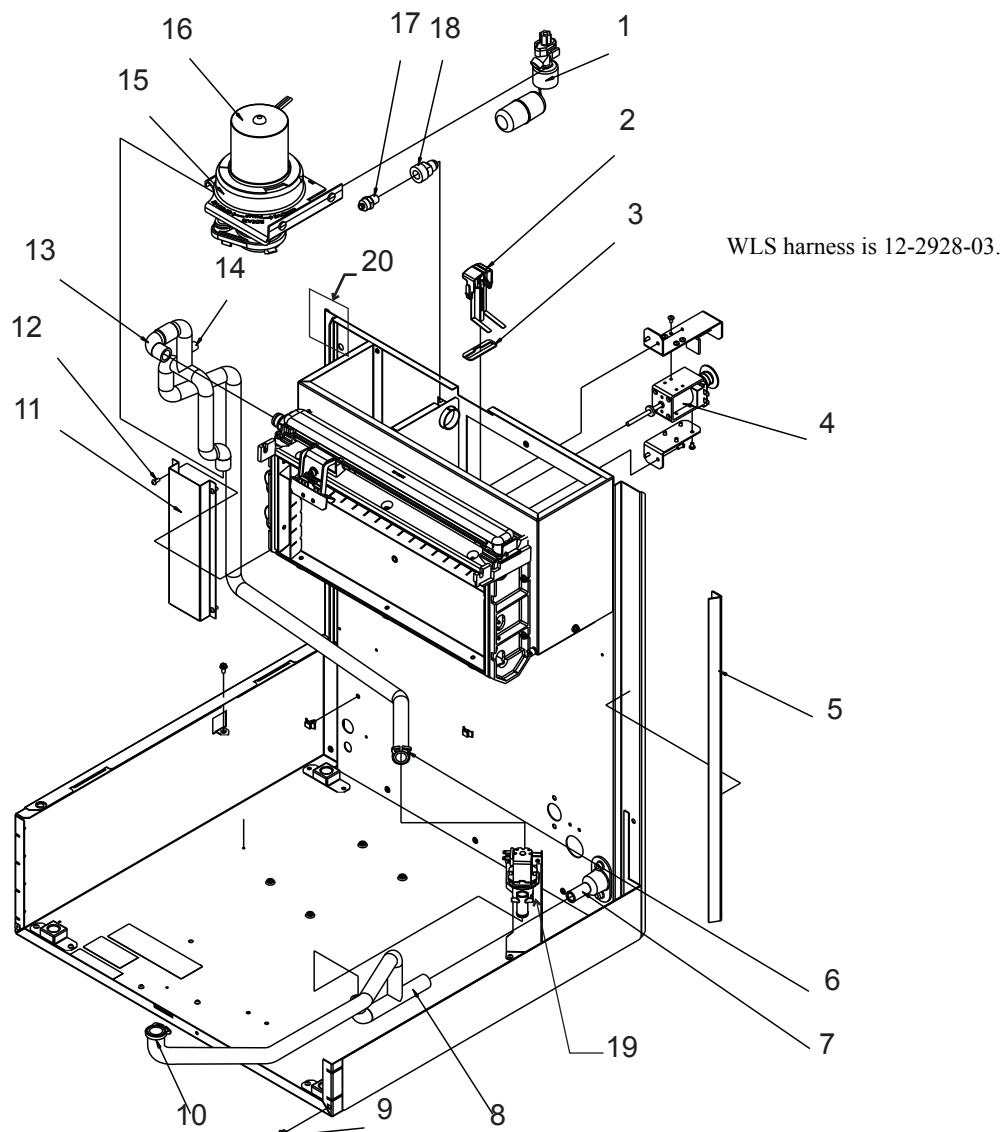

Item	Part Number	Description
1	02-3612-01	Float valve, with shut off
	02-4652-01	Float valve, no shut off
1a	13-0895-01	Inlet tubing, order 2, cut to 15"
2	A39126-021	Water level sensor
3	A39143-001	Spacer
4	12-3060-21	Harvest assist solenoid, 115 v
	12-3060-22	Harvest assist solenoid, 230
		Includes mounting brackets
5	02-4491-01	Gasket, corner
6	02-2814-09	Hose clamp
7	02-3692-21	Drain fitting
8	A39144-001	Drain hose, 26" model
9	03-3804-01	Screw receptacle
11	A39151-001	Chase cover
12	03-1531-01	Screw
13	02-4299-01	Pump hose, 26" model
14	11-0515-21	Temp sensor set
15	02-4318-01	Pump bracket
16	12-2919-21	Water pump, 115 volt models
	16a	12-2919-22 Water pump, 230 volt models
	17	16-1039-01 Male connector
	18	16-0835-01 Water inlet fitting, 3/8 flare
	19	11-0564-01 Purge valve, 115 volt models
	19a	11-0564-02 Purge valve, 230 volt models
	20	13-0954-01 Foam pad, 2" x 2"

# CU1526, CU2026, CU3030 Service Parts

## CU1526 and CU2026 Air Cooled Refrigeration

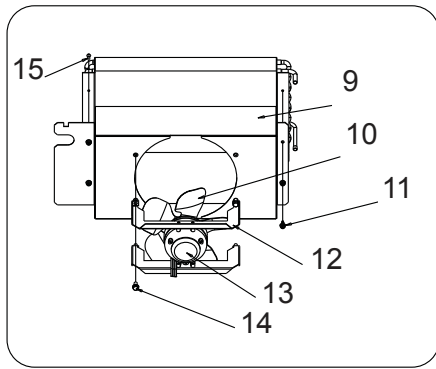

Condenser Fan

Compressor terminal adapter, 12-3008-01.  
Contains no contacts or electronics.

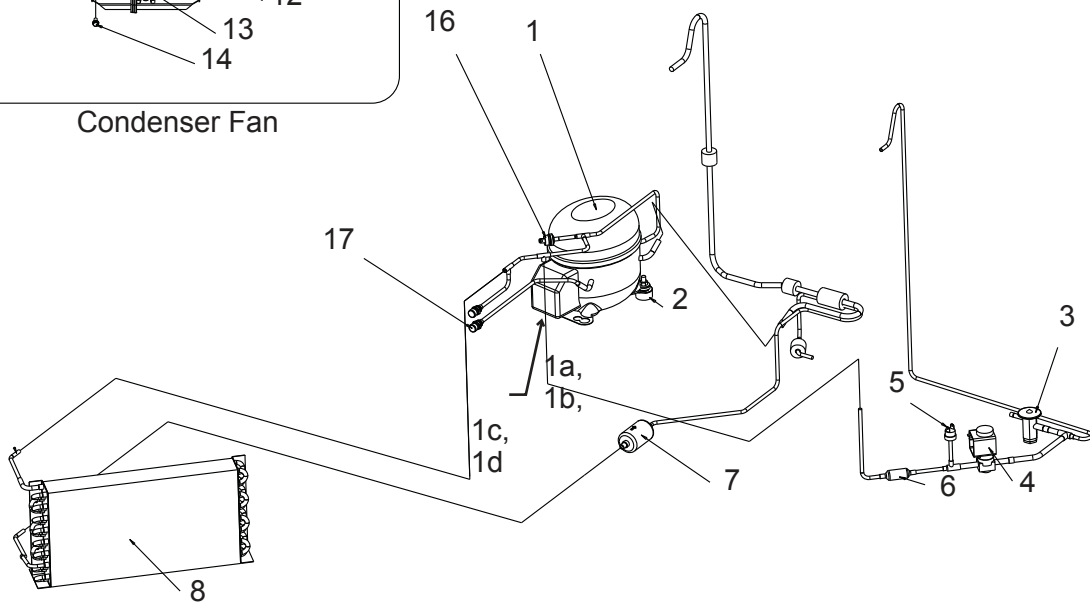

Item	Part Number	Description	7	02-3319-01	Dryer
1		Compressors*	8	18-8942-01	Condenser
		18-8932-21 CU1526 115/60	9	A39084-001	Shroud
1a	18-8932-31	Overload for above	10	18-8773-01	Fan blade
		18-8932-26 CU1526 230/50	11	03-3868-01	Screw
1b	18-8932-32	Overload for above	12	A39113-001	Bracket, motor
		18-8933-21 CU2026 115/60	13	Fan motors	
1c	18-8933-31	Overload for above		12-2989-01	CU1526, 115/60
		18-8933-22 CU2026, 208-230/60		12-2989-02	CU1526, 230/50
		18-8933-26 CU2026, 208-230/50		12-1681-23	CU2026, 115/60
		18-8957-21 CU2026, 115V/60HZ, E Series		12-1681-04	CU2026, 208-230/60-50
1d	18-8933-32	Overload for above	14	03-1645-01	Screw
2		Compressor mounting hardware	15	03-1531-01	Screw
	03-1406-10	Hex nut	16	11-0501-05	Hi pressure cut out
	03-3900-01	Screw (up thru base)	17	16-1140-01	Port cap
	18-0108-41	Sleeve		16-1139-01	Core
	18-4700-28	Grommet		16-1138-01	Seat
	03-1407-07	Washer			
3	16-1183-02	TXV - Danfoss			
	19-0599-01	Insulation for TXV			
4	11-0493-04	Hot gas valve, 115/60			
	12-2719-21	Coil only, 115 volt			
	11-0493-05	Hot gas valve, 230/60-50			
	12-2719-22	Coil only, 230 volt			
	12-2733-30	HGV rebuild kit			
5	11-0566-21	Fan control pressure switch			
6	16-1063-02	Strainer -discontinued 2011			

\* Compressors include overload, run capacitor, PTCR and dryer

# CU1526, CU2026, CU3030 Service Parts

## CU1526 and CU2026 Water Cooled Refrigeration

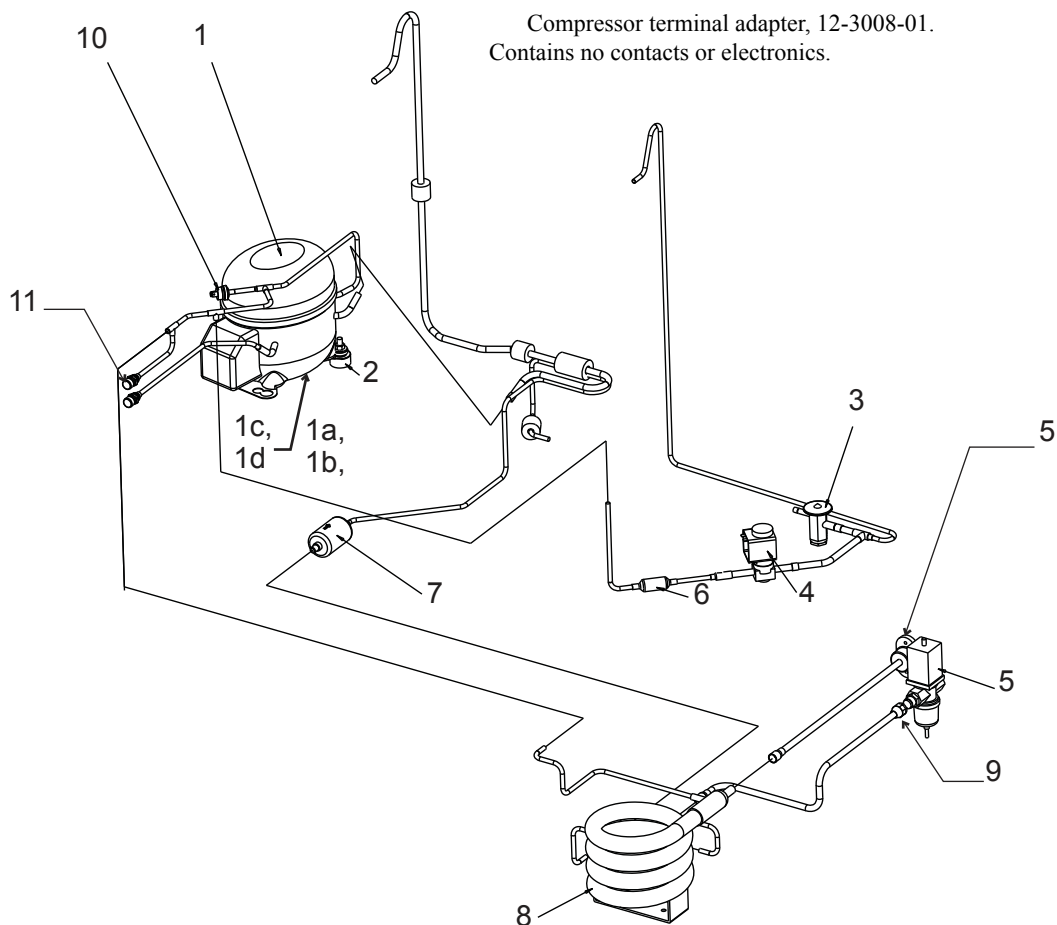

Item	Part Number	Description
1		Compressors*
	18-8932-21	CU1526 115/60
1a	18-8932-31	Overload for above
	18-8932-26	CU1526 230/50
1b	18-8932-32	Overload for above
	18-8933-21	CU2026 115/60
1c	18-8933-31	Overload for above
	18-8933-22	CU2026, 208-230/60
	18-8933-26	CU2026, 208-230/50
1d	18-8933-32	Overload for above
2		Compressor mounting hardware
	03-1406-10	Hex nut
	03-3900-01	Screw (up thru base)
	18-0108-41	Sleeve
	18-4700-28	Grommet
	03-1407-07	Washer
	316-1183-02	TXV - Danfoss
	19-0599-06	Insulation for TXV
4	11-0493-04	Hot gas valve, 115/60
	12-2719-01	Coil only, 115 volt
	11-0493-05	Hot gas valve, 230/60-50
	12-2719-02	Coil only, 230 vol
	12-2733-30	HGV rebuild kit
5	11-0608-21	Water regulating valve
6	16-1063-02	Strainer - discontinued 2011
7	02-3319-01	Dryer
8	18-8869-01	Condenser
9	16-0355-00	Coupling half
10	11-0501-01	Hi pressure cut out - WC
11	16-1140-01	Port cap
	16-1139-01	Core
	16-1138-01	Seat

\* Compressors include overload, run capacitor, PTCR and dryer.

**CU1526, CU2026, CU3030 Service Parts**  
**CU1526 and CU2026 Ice Making Area**

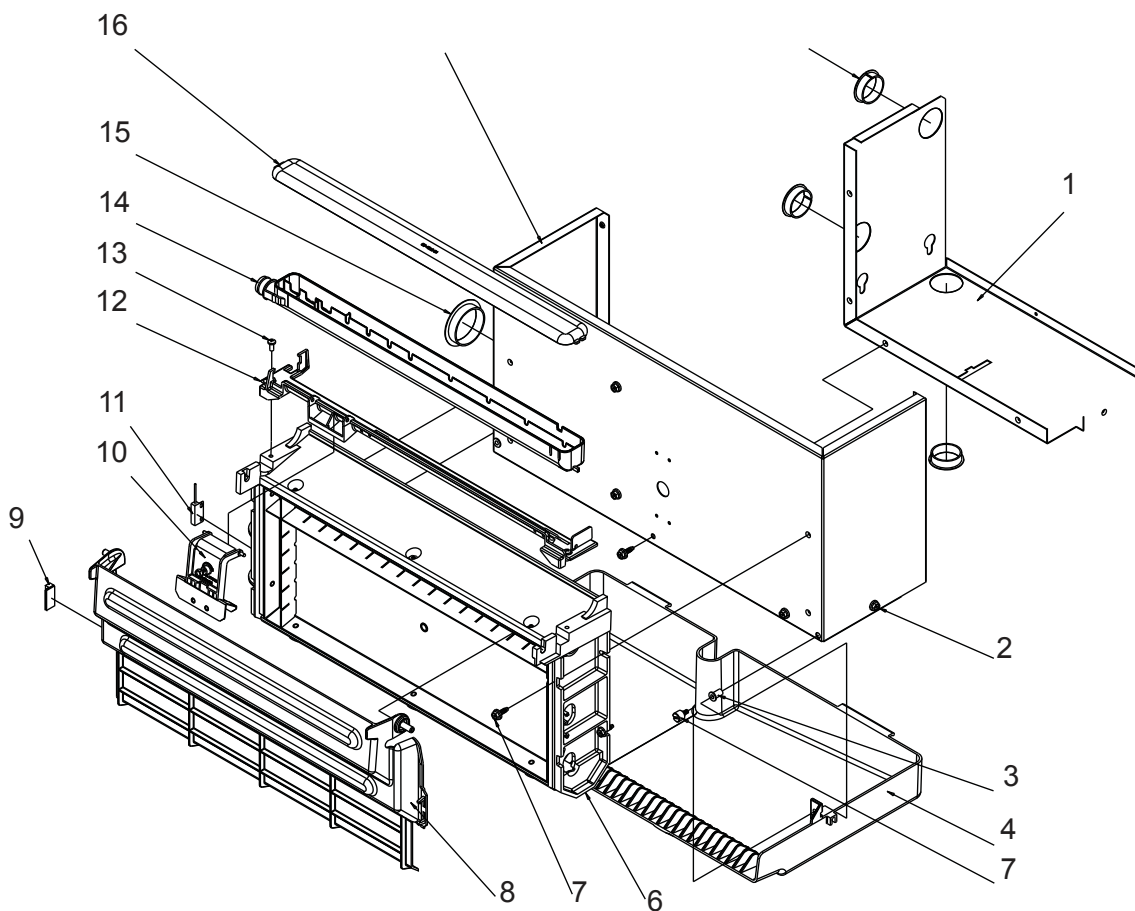

Item	Part Number	Description
1	A39090-001	Support
2	03-3868-01	Screw
3	03-1692-01	Insert
4	02-4315-01	Reservoir
5	A39091-001	Evaporator mounting bracket
6	A38626-021	Evaporator, small cube
	A38626-022	Evaporator, med cube
7	03-3868-01	Screw
8	02-4307-01	Curtain - no mag
9	11-0563-05	Magnet
10	A39031-021	Ice thickness sensor
11	11-0563-04	Curtain switch
12	02-4205-01	Mounting bracket
13	03-1403-15	Screw
14	02-4064-01	Water distributor
15	12-1213-15	Snap bushing
16	02-4065-01	Water distributor cover

# CU1526, CU2026, CU3030 Service Parts

## CU1526 and CU2026 Electrical

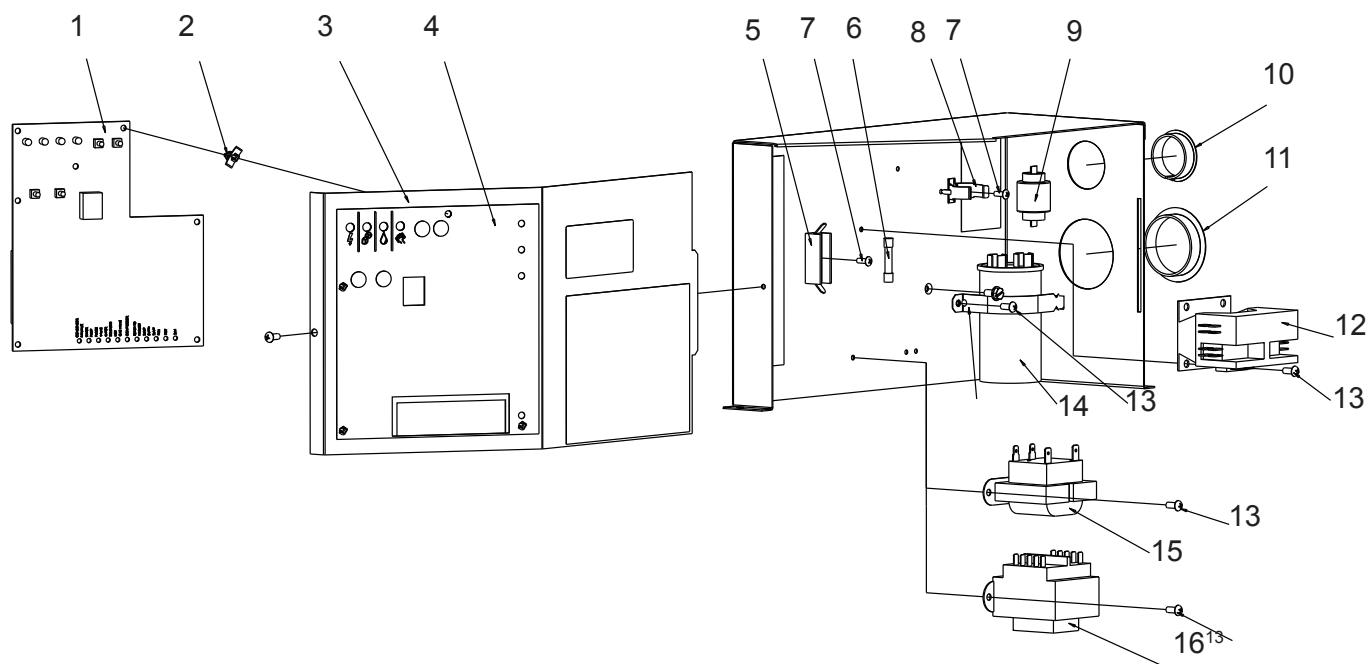

Item	Part Number	Description	Not Shown	
1	11-0550-28	Controller	NS1	12-2959-01 High voltage harness - 60 Hz
2	03-1727-02	Stand off	NS2	12-2988-01 High voltage harness - 50 Hz
3	A39081-001	Control box cover	NS3	12-2931-01 Control power harness - 60 Hz
4	02-4302-01	Overlay	NS4	12-2944-01 Control power harness - 50 Hz
5	12-2687-01	Fuse block, 50 Hz only	NS5	12-1638-14 Power cord, 115/0
6	12-2686-01	Fuse, 50 Hz only	NS6	12-1638-18 Power cord, 208-230/60
7	03-1638-06	Screw	NS7	12-1638-22 Power cord, 230/0
8	18-8835-02	Bracket, PTCR	NS8	12-3020-01 Harness, On/Off switch to connector*
9	18-8835-01	PTCR	NS8A	12-3020-02 Harness, item NS8 to transformer*
10	12-1213-13	Snap bushing	NS9	12-2936-01 Fan motor harness
11	12-1213-15	Snap bushing	NS10	12-2930-01 Harness, contactor to compressor
12	12-2469-03	Contactor, 115/60	NS11	12-2928-03 WLS harness
	12-2469-02	Contactor, 230/60-50		
13	03-1531-01	Screw		
14	18-1902-68	Run capacitor, for all but CU2026-6		
	18-8878-01	Run capacitor, CU2026 50 Hz		
15	12-2924-01	Transformer, 115 to 12		
	12-2924-02	Transformer, 60 Hz, 230 to 12		
16	12-2639-01	Transformer, 50 Hz, 230 to 12		

\* Early switch harness was one piece, changed Sept 08 to include a connector. Order both NS8 and NS8A to replace early harness. NS8 and NS8A not used after on off switch disconnected.



# CU1526, CU2026, CU3030 Service Parts

## CU3030 Cabinet

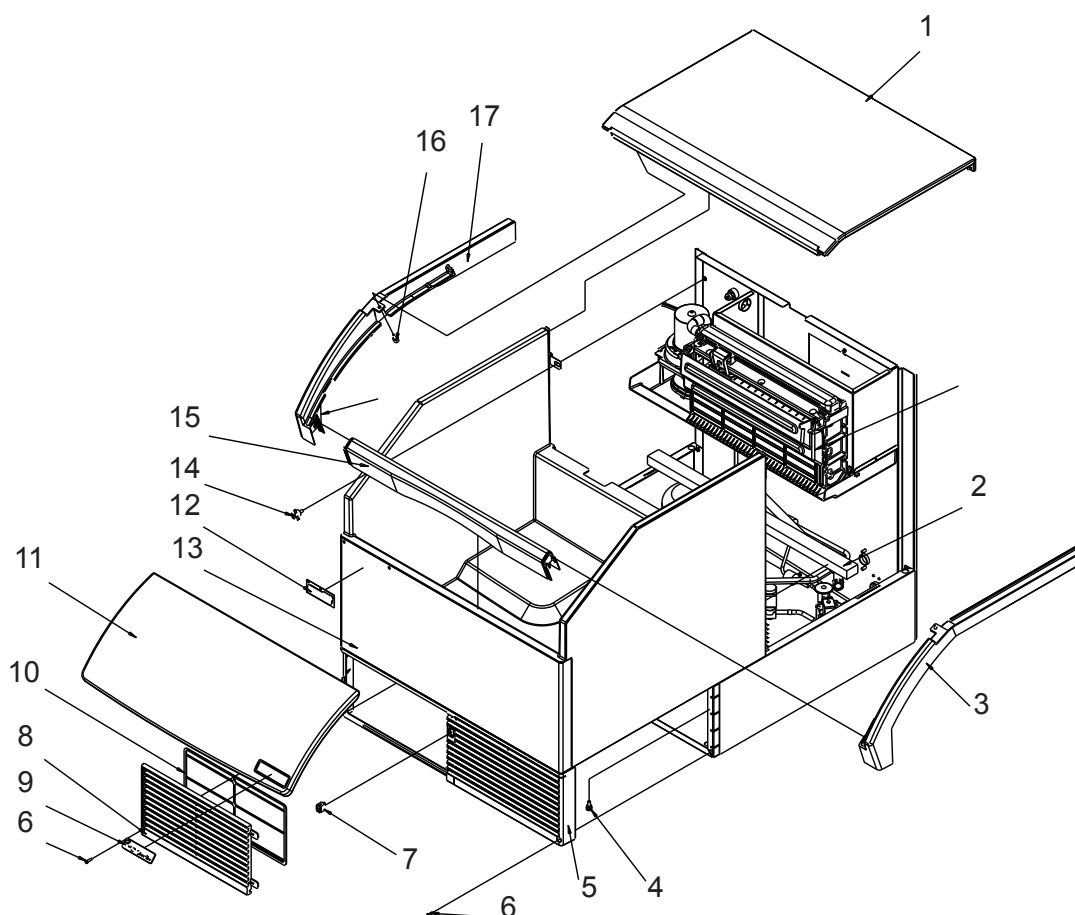

Item	Part Number	Description		
			03-1419-17	Screw, rail attachment
1	A39133-001	Top panel		
2	19-0655-01	Gasket, AC only	Not Shown	
3	02-4310-02	Right rail, 30" model	NS1	02-3253-01 Scoop
4	03-0727-10	Thumb screw	NS2	KLP7 Legs - set of 4
5	02-4303-01	Right grill/frame, 30" model*	NS3	16-1150-01 Fitting, 50 Hz models
6	03-1404-12	Screw	NS4	03-3901-01 Washer, 50 Hz models
7	12-2991-01	On/Off switch		
8	02-4303-02	Left grill/insert, 30" model		
9	15-0825-01	Emblem		
10	02-4308-02	Filter, front, 30" model		
11	02-4314-20	Door		
12	15-0824-01	Prodigy emblem		
13	A39121-021	Bin assembly, Includes items 3, 12, 15, 17		
14	03-1675-02	3 prong head screw		
15	02-4312-02	Frame front		
16	03-3892-01	Screw, bin to top		
17	02-4310-01	Left rail, 30" model		

Note: Frame rail attachment to bin wall changed late 2008 from adhesive only to screws and adhesive. Screw used is #6 x 5/8 flat head. When replacing frame rail on prior bin, use 1/8" dia drill bit to create mounting holes in top of bin wall.

\* Part changed 2012, no spot for on-off switch. If replacing grill on unit with switch, mount switch to notch in access valve bracket.

## CU1526, CU2026, CU3030 Service Parts CU3030 Back and Base

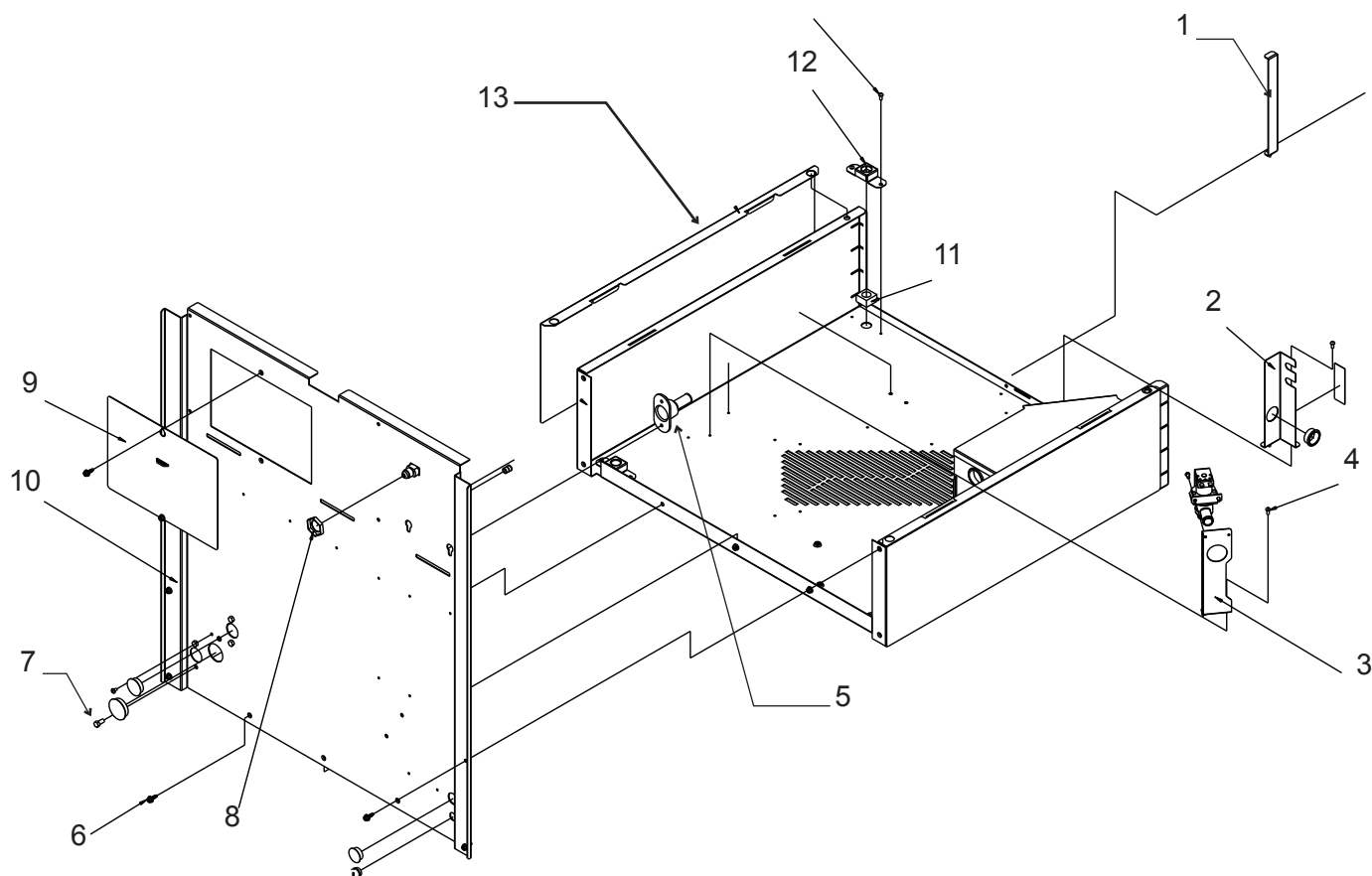

Item	Part Number	Description
1	A39145-001	Baffle, AC
2	A39086-001	Bracket, access valves
3	A39092-001	Bracket, purge valve
4	03-1531-01	Screw
5	02-3692-21	Drain fitting
6	03-3868-01	Screw
7	03-0571-00	Screw
8	03-1394-01	Pal nut
9	A39142-001	Service panel
10	A40253-001	Back panel, 30" model
11	03-1674-01	Nut, leg mounting
12	A39083-001	Bracket, nut
13	A39096-001	Overlay panel, attach with adhesive tape, item 13a 2 feet.
13a	19-0642-02	Adhesive tape, order by foot

## CU1526, CU2026, CU3030 Service Parts CU3030 Ice Making Area

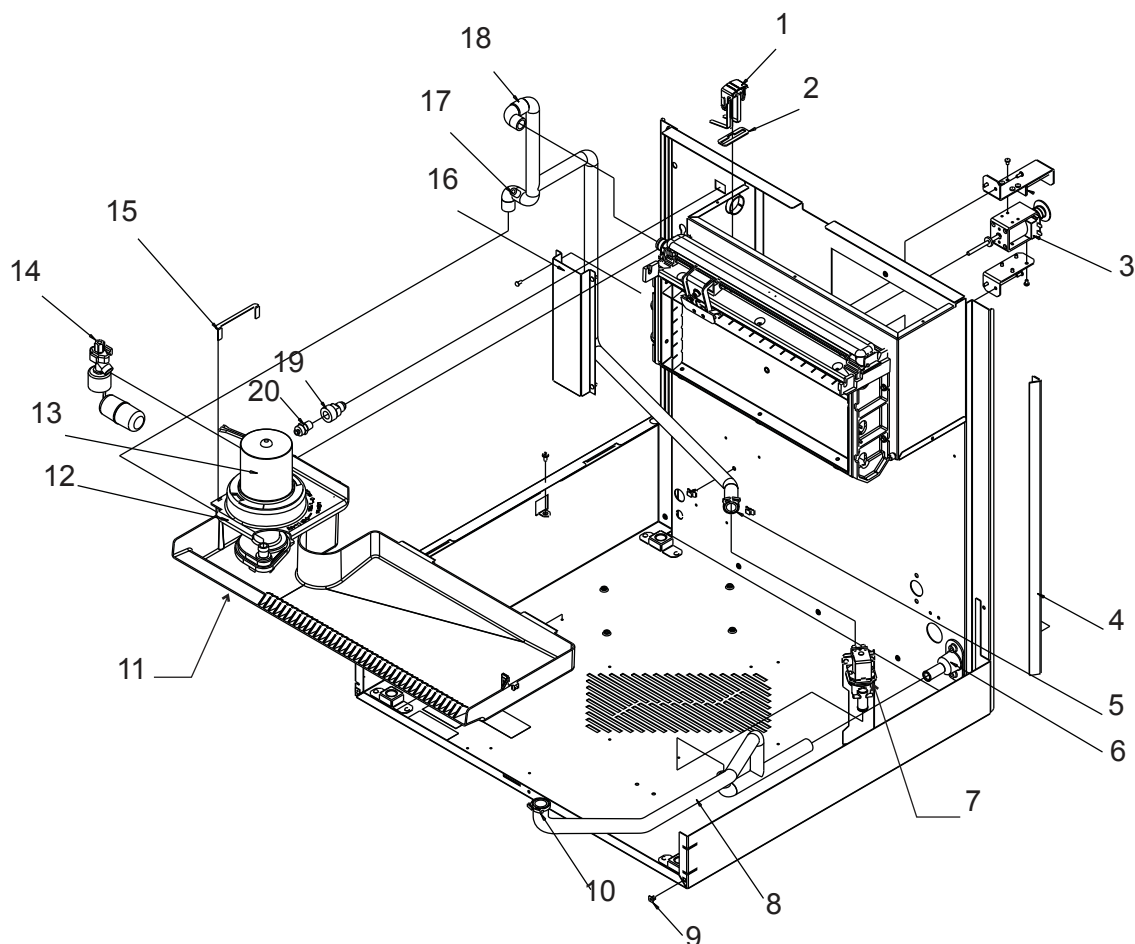

Item	Part Number	Description
1	A39126-021	Water level sensor
2	A39143-001	Spacer
3	12-3035-21	Harvest assist solenoid, 115v
	12-3035-22	Harvest assist solenoid, 230 v
		Includes mounting brackets
4	02-4491-01	Corner gasket
5	02-2814-09	Hose clamp
6	02-3692-21	Drain fitting
7	11-0564-01	Purge valve, 115 volt models
	11-0564-02	Purge valve, 230 volt models
8	02-4301-01	Drain hose, 30" models
9	03-3804-01	Screw receptacle
10	02-2814-10	Hose clamp
11	02-4316-01	Reservoir, 30" models
12	02-4318-01	Pump bracket
13	12-2919-21	Water pump, 115 volt models
	12-2919-22	Water pump, 230 volt models
14	02-3612-01	Float valve, with shut off
	02-4652-01	Float valve, no shut off
15	A39152-001	Snap alignment clip
16	A39151-001	Chase cover
17	11-0515-21	Temp sensor set
18	02-4300-01	Pump hose
19	16-0835-01	Water inlet fitting, 3/8 flare
20	16-1039-01	Male connector

# CU1526, CU2026, CU3030 Service Parts

## CU3030 Air Cooled Refrigeration

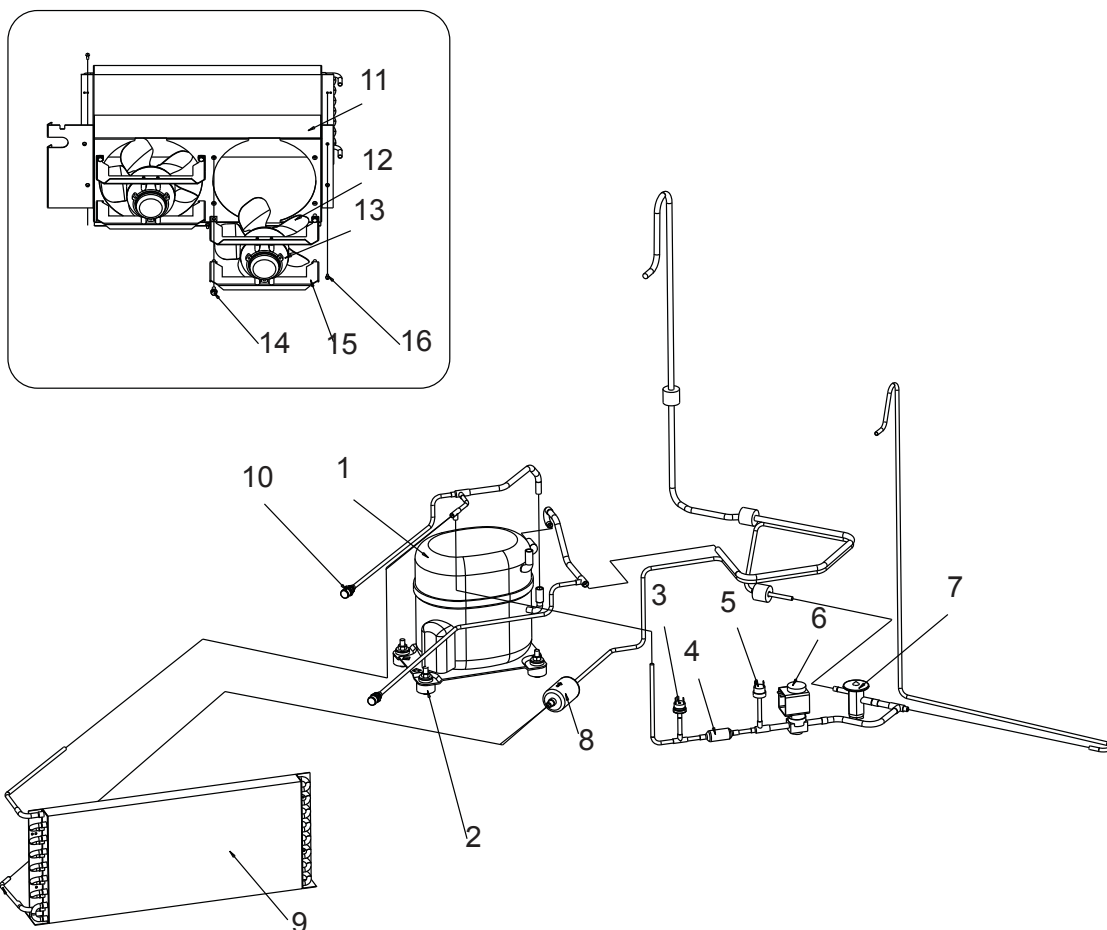

Item	Part Number	Description	Part Number	Description
1		Compressors*	11-0493-01	Hot gas valve, 230/60-50
			12-2719-22	Coil only, 230/60-50
	18-8954-21	CU3030 comp. 115/60	12-2733-30	HGV rebuild kit
1a	18-8954-50	Overload for above	7	16-1183-02 TXV - Danfoss
	18-8954-22	CU3030 comp. 208-230/60		19-0599-06 Insulation for TXV
1a	18-8954-51	Overload for above	8	02-3319-01 Dryer
	18-8954-26	CU3030 comp. 230/50	9	18-8934-01 Condenser
1a	18-8954-53	Overload for above	10	16-1140-01 Port cap
2		Compressor mounting hardware		16-1139-01 Core
	03-1406-10	Hex nut		16-1138-01 Seat
	03-3900-01	Screw (up thru base)	11	A39095-001 Fan shroud
	18-0108-41	Sleeve	12	18-8773-01 Fan blade
	18-4700-28	Grommet	13	12-1681-23 Fan motor, 115/60
	03-1407-07	Washer		12-1681-04 Fan motor, 208-230/60-50
3	11-0501-05	Hi pressure cut out	14	03-1645-01 Screw
4	16-1063-02	Strainer - discontinued 2011	15	A39113-001 Bracket, motor
5	11-0566-21	Fan control pressure switch	16	03-1531-01 Screw
6	11-0493-02	Hot gas valve, 115/60		
	12-2719-21	Coil only, 115/60		

\* Compressors include run capacitor, PTCR and dryer.

# CU1526, CU2026, CU3030 Service Parts

## CU3030 Water Cooled Refrigeration

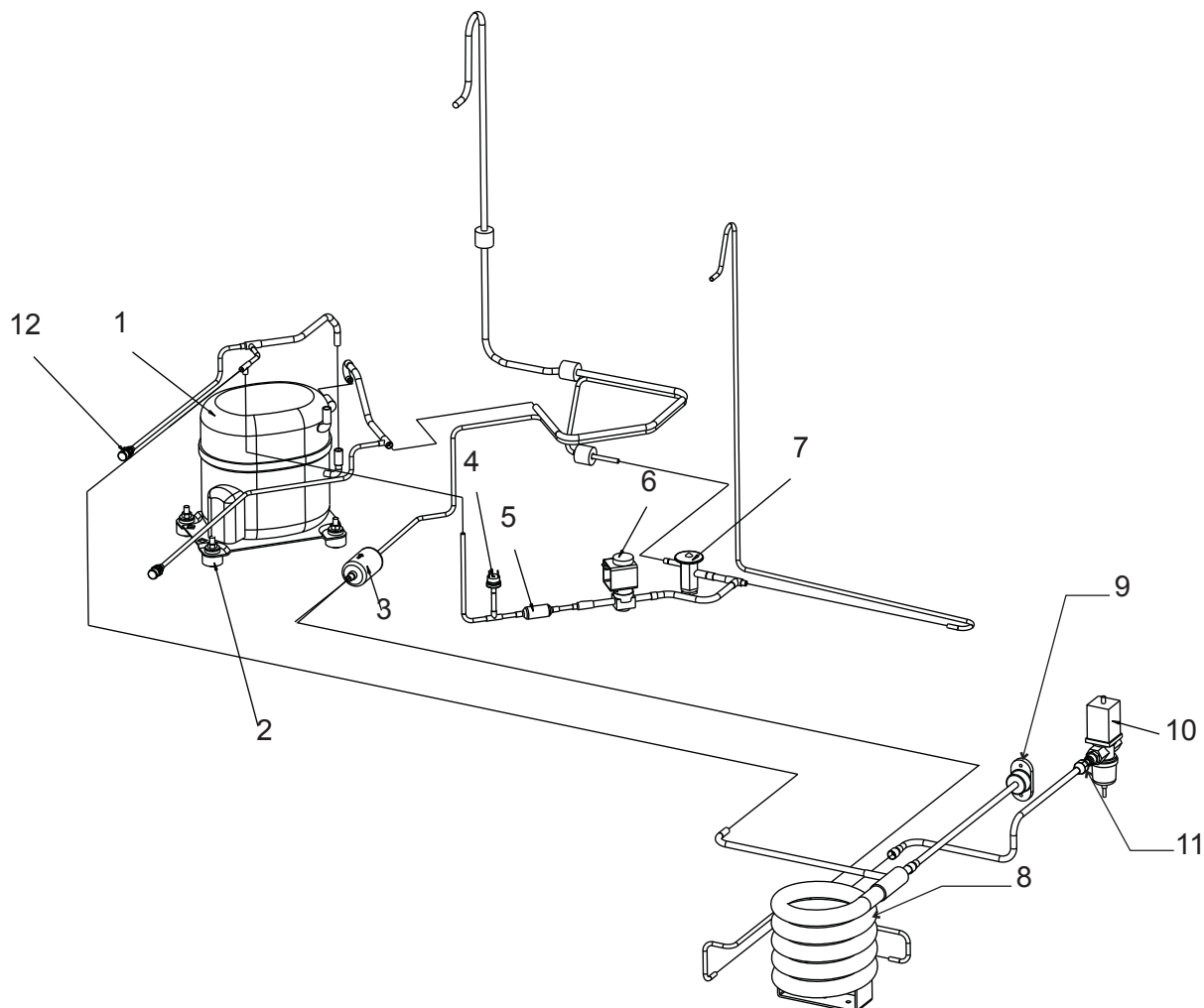

Item	Part Number	Description			
1		Compressors*		11-0493-01	Hot gas valve, 230/60-50
				12-2719-22	Coil only, 230/60-50
	18-8954-21	CU3030 comp. 115/60		12-2733-30	HGV rebuild kit
1a	18-8954-50	Overload for above	7	16-1183-02	TXV - Danfoss
	18-8954-22	CU3030 comp. 208-230/60		19-0599-06	Insulation for TXV
1a	18-8954-51	Overload for above	8	18-8871-01	Water cooled condenser
	18-8954-26	CU3030 comp. 230/50	9	A31828-002	Drain fitting
1a	18-8954-52	Overload for above	10	11-0608-21	Water regulating valve
2		Compressor mounting hardware	11	16-0355-00	Coupling half
	03-1406-10	Hex nut	12	16-1140-01	Port cap
	03-3900-01	Screw (up thru base)		16-1139-01	Core
	18-0108-41	Sleeve		16-1138-01	Seat
	18-4700-28	Grommet			
	03-1407-07	Washer			
3	02-3319-01	Dryer			
4	11-0501-01	Hi pressure cut out			
5	16-1063-02	Strainer - Discontinued 2011			
6	11-0493-02	Hot gas valve, 115/60			
	12-2719-21	Coil only, 115/60			

\* Compressors include run capacitor, PTCR and dryer.

**CU1526, CU2026, CU3030 Service Parts**  
**CU3030 Ice Making Area**

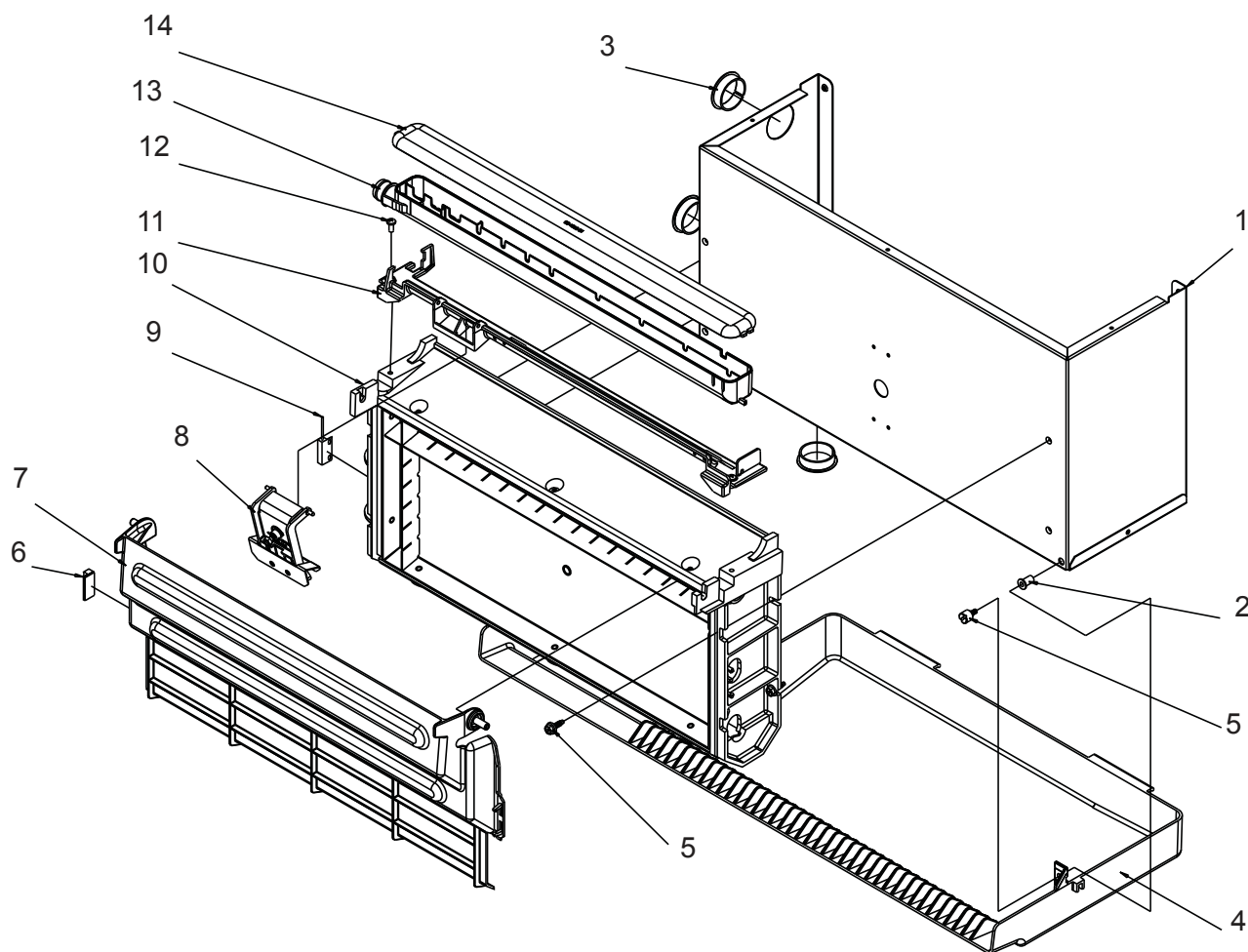

Item	Part Number	Description
1	A39094-001	Evaporator mounting bracket
2	03-1692-01	Insert
3	12-1213-13	Snap bushing
4	02-4316-01	Reservoir
5	03-3868-01	Screw
6	11-0563-05	Magnet
7	02-4307-01	Curtain - no mag
8	A39031-001	Ice thickness sensor
9	11-0563-04	Curtain switch
10	A38626-021	Evaporator, small cube
	A38626-022	Evaporator, med cube
11	02-4205-01	Mounting bracket
12	03-1403-15	Screw
13	02-4064-01	Water distributor
14	02-4065-01	Water distributor cover

## CU1526, CU2026, CU3030 Service Parts CU3030 Electrical

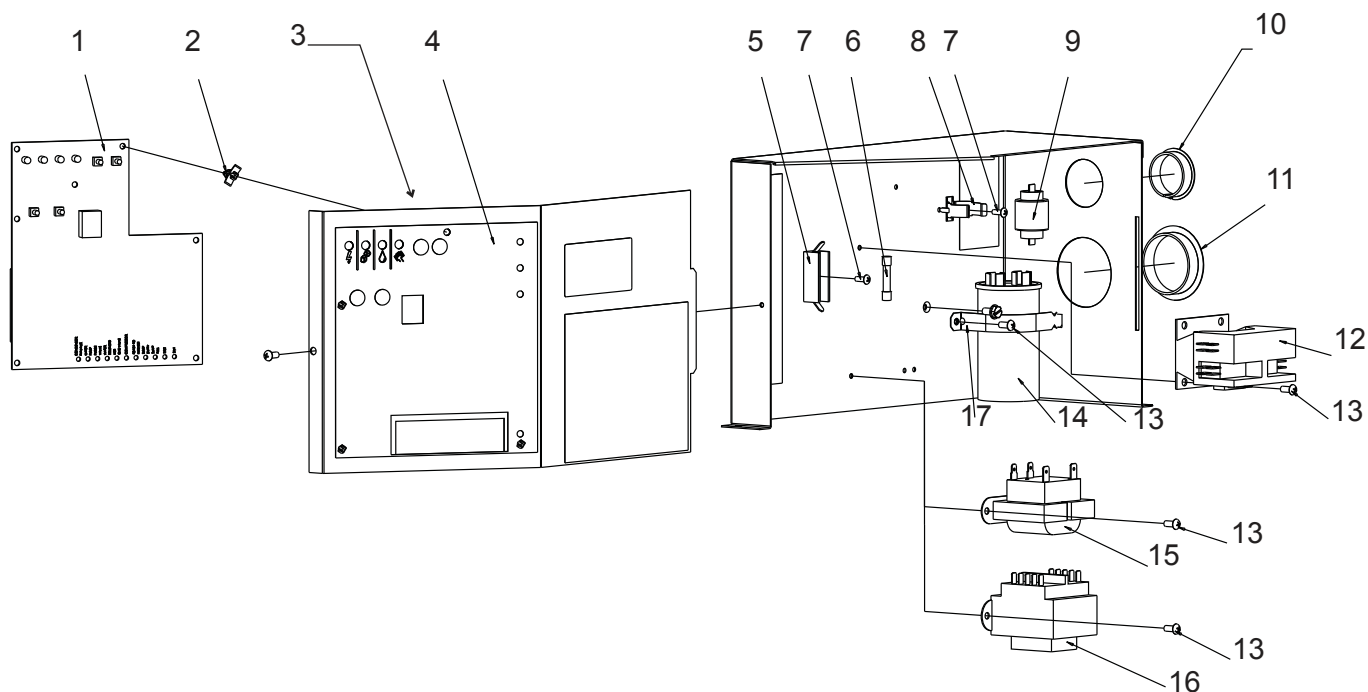

Item	Part Number	Description
1	11-0550-28	Controller
2	03-1727-02	Stand off
3	A39081-001	Control box cover
4	02-4302-01	Overlay
5	12-2687-01	Fuse block, 50 Hz only
6	12-2686-01	Fuse, 50 Hz only
7	03-1638-06	Screw
8	18-8835-02	Bracket, PTCR
9	18-8835-01	PTCR
10	12-1213-13	Snap bushing
11	12-1213-15	Snap bushing
12	12-2469-03	Contactator, 115/60
	12-2469-02	Contactator, 230/60-50
13	03-1531-01	Screw
14	18-1902-53	Run capacitor - 115 volt model
	18-1902-68	Run cap - 208-230 volt models
15	12-2924-01	Transformer, 115 to 12
	12-2924-02	Transformer, 60 Hz, 230 to 12
16	12-2639-01	Transformer, 50 Hz, 230 to 12
17	A37651-001	Strap, capacitor
	Not Shown	
	NS1	12-2959-01 High voltage harness - 60 Hz
	NS2	12-2988-01 High voltage harness - 50 Hz
	NS3	12-2931-01 Control power harness - 60 Hz
	NS4	12-2944-01 Control power harness - 50 Hz
	NS5	12-1638-14 Power cord, 115/60
	NS6	12-1638-18 Power cord, 208-230/60
	NS7	12-1638-22 Power cord, 230/50
	NS8	12-3020-01 Harness, On/Off switch to connector*
	NS8A	12-3020-02 Harness, item NS8 to transformer*
	NS9	12-2936-01 Fan motor harness

\* Early harness was one piece, changed Sept 08 to include a connector. Order both NS8 and NS8A to replace early harness.